

Mooney* 4" Flowgrid* Slam Shut

Flanged CL 150, 300

The 4" Mooney Slam Shut is a unique pneumatically actuated device that automatically provides downstream pressure protection. By separating the pneumatic controller and mechanical latching mechanism, shutoff is guaranteed to occur only when designated set points are reached. The patent pending design prevents disruptive and costly "accidental shutoffs". Positive shutoff is achieved instantly through the snap acting mechanism, and reset can be completed with common tools.



Flowgrid Regulator with Integral Shutoff Valve, Series 50D Dual Function Controller.

Specifications

Size	4"
Body Style	Single Port
End Connections	4"CL 150 RF Flange, 4" CL 300 RF Flange, 150/300 Butt weld
Temperature	Working -20°F to 150°F (-29°C to 65°C)
Maximum Inlet Pressure	740 psig (50 bar)
Outlet Pressure Range	Limited by SSV Controller
Flow Direction	Uni-Directional
Body Taps	Four 1/4" - 18 NPT (one inlet, one center port ¹⁾ , one loading and one downstream)

1) Center port - between flapper valve and regulator

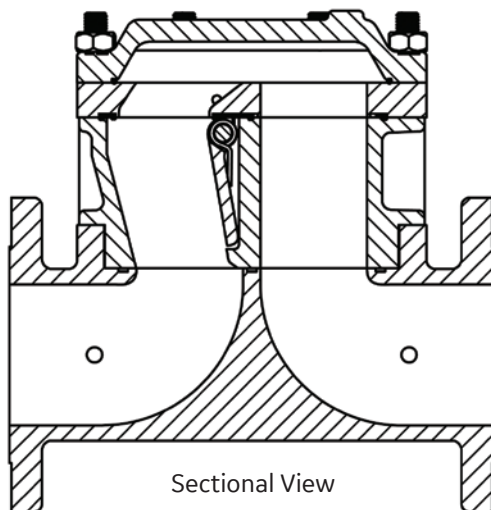

Materials of Construction

Body, Seal Retainer and Flapper Body	ASTM A 216 GR WCB Carbon Steel
Cap	ASTM A 516 Carbon Steel
Flapper and Shaft	17-4 PH Stainless Steel
O-Ring and Seals	Nitrile, Optional Viton®
Studs and Nuts	ASTM A 193 GR B-7 ASTM A 194 GR 2H or Equal
Springs	ASTM A 313-03 17-17 SS
Bushings	Acetal

Stock Numbers

4" Slam Shut	Stock Number	Weight
150# Flange	SA-39	163 lbs.
300# Flange	SA-40	178 lbs.
150/300 Butt weld	SA-63	146 lbs.

Dimensions

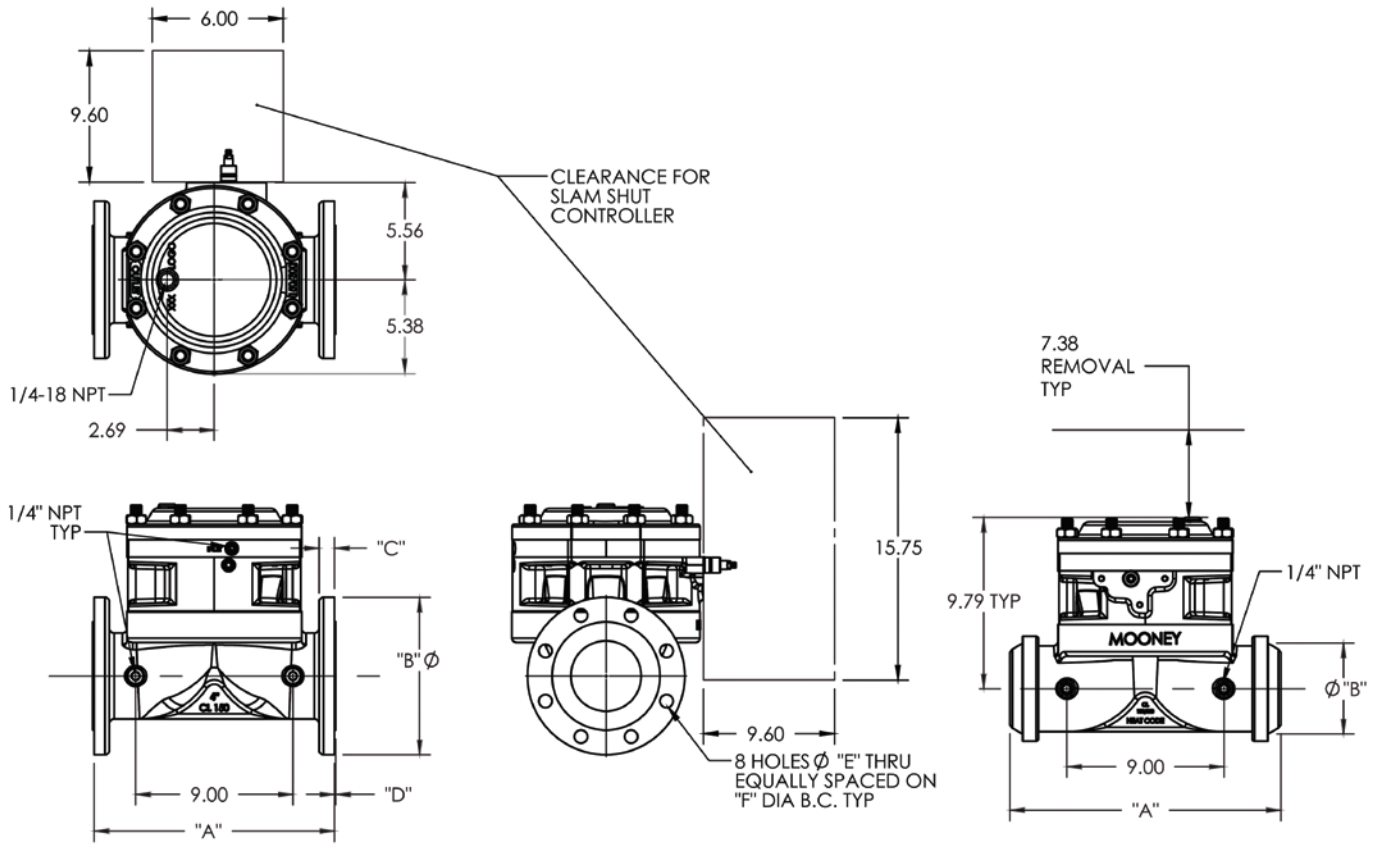

Flange Dimensions

Flange Class	A	B	C	D	E	F
Class 150	13.88	9.00	1.00	.62	7.50	7.50
Class 300	14.50	10.00	1.25	.62	8.75	7.87
Buttweld	15.50	5.19	-	-	-	-

Flow Coefficients and Constants⁽¹⁾

3" Mooney Slam Shut		
C _v	C ₁	C _B
192	38	7000

1) Preliminary Data

bhge.com

*Denotes a trademark of Baker Hughes, a GE company LLC.

Other company names and product names used in this document are the registered trademarks or trademarks of their respective owners.

© 2018 Baker Hughes, a GE company LLC - All rights reserved.

Baker Hughes reserves the right to make changes in specifications and features shown herein, or discontinue the product described at any time without notice or obligation. Contact your BHGE representative for the most current information. The Baker Hughes logo is a trademark of Baker Hughes, a GE company. The GE Monogram is a trademark of the General Electric Company.

GEA34057 12/2018

**BAKER
HUGHES**
a GE company

